

LUMALARM

BACK UP ALARM | 97dB



SAE / DOT.

Multi-functional back up alarm with flashing amber LED warning lights.
Night silent function for use in sound sensitive areas.

Applications include: Dump Trucks, Forklifts, Construction Vehicles, Mining Vehicles, Semi-Trailers.

FEATURE	BENEFIT
Night silent	Alarm can be disengaged when in sound sensitive areas. Flashing amber LED warning stays on warning pedestrians of vehicle presence.
200 lumen amber LED	Provides bright visual warning of vehicle backing up in addition to audible alarm.
Wraparound LED lens	Flashing amber LED warning visible beyond 180° on either side of back up alarm, providing added safety.
ABS housing	Robust construction for heavy duty applications.
Epoxy encapsulated electronics	Electronic components are protected against environmental elements.

LUMALARM

BACK UP ALARM | 97dB



Part #	Description	Decibels	Operating Voltage
23705-52051	Lumalarm LED Back Up Alarm	97dB	12 - 24Vdc

Specifications:

Lumens: 200
 Operating Voltage: 12 - 24Vdc
 Operating Current: 500mA @ 12Vdc
 250mA @ 24Vdc
 Temperature Range: -40°C to +85°F
 Weight: 04lbs (0.2kg)
 Housing: Black ABS
 Lens: PMMA Clear Optical Grade
 Connection: 5 Wires
 SAE / DOT: SAE J994

Modes						Alarm	LEDs
Normal Alarm	+				-	✓	✓
Night Silent	+	+			-		✓
Override Night Silent	+	+	+		-	✓	✓
Alarm Only	+			+	-	✓	
Flashing Amber Only	+		+		-		✓

+ 12Vdc - Ground

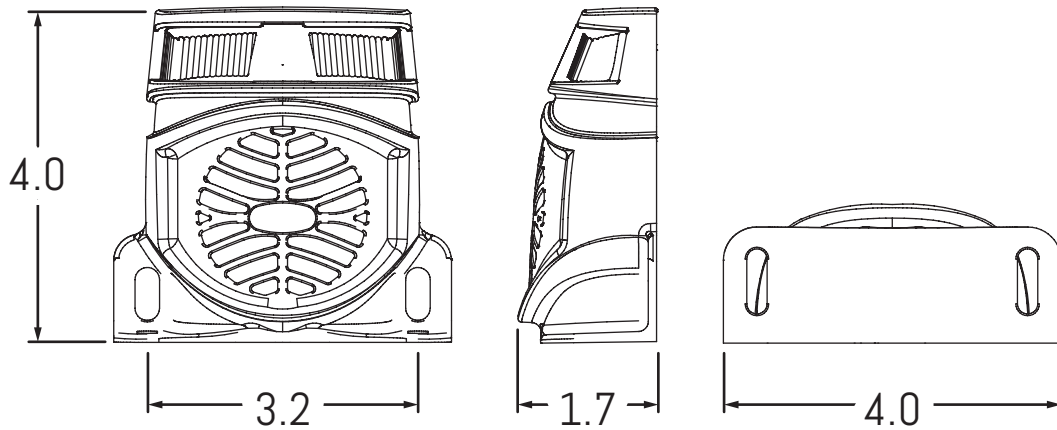

A.R.E. lighting and electronic products must be fused appropriately in all instances. If you are in doubt, consult with an A.R.E. service representative at 1-800-649-4ARE or email contact@4are.com.
 NOTE: Improperly fused/installed product will invalidate the warranty.